



# 60cc MINISWIFT "PROMOTIONAL" - TAG (B)

		FEATURES - CARACTERISTIQUES	
		Cylinder Volume <i>Volume du cylindre</i>	59.00 cm <sup>3</sup>
		Bore <i>Alésage</i>	41.80 mm
		Max. bore <i>Alésage max.</i>	42.10 mm
		Max. Stroke <i>Course max.</i>	43.15 mm
		Cooling system <i>Système de refroidissement</i>	Air <i>Air</i>
		Inlet system <i>Système d'admission</i>	Piston valve <i>Jupe de piston</i>
		Number of carbs <i>Nombre de carburateurs</i>	1
Tillotson Carburettor <i>Carburateur Tillotson</i>	<b>HW-31A</b> (ØVenturi 17mm)	Cylinder / crankcase transfers n° <i>N° de canaux cylindre / carter</i>	2 / 2
Number of piston rings <i>Nombre de segments</i>	1	Inlet / exhaust ports number <i>N° lumières admiss / échapp.</i>	1 / 1
Big end conrod ball-bearing diam. <i>Diamètre palier tête de bielle</i>	18x24x15	Combustion chamber shape <i>Forme chambre de combustion</i>	Spherical <i>Sphérique</i>
Crankshaft ball-bearing diam. <i>Diamètre palier du vilebrequin</i>	20x47x14	Selettra ignition (adjustable) <i>Allumage Selettra (réglable)</i>	Analogue 2 Poles
Small end conrod ball-bearing diam. <i>Diamètre palier pied de bielle</i>	12x16x16	Distance between Conrod centers <i>Longueur (entre axe) de la bielle</i>	88 mm

DESCRIPTION OF THE MATERIAL <i>DESCRIPTION DES MATERIAUX</i>		PISTON
Conrod material <i>Matériel de la bielle</i>	Steel <i>Acier</i>	
Crankshaft material <i>Matériel du vilebrequin</i>	Steel <i>Acier</i>	
Head Material <i>Matériel de la culasse</i>	Aluminium	
Cylinder Material <i>Matériel du cylindre</i>	Aluminium	
Liner material <i>Matériel de la chemise</i>	Iron <i>Fonte</i>	DISTANCE BETWEEN CONROD CENTERS <i>ENTRE AXE DE LA BIELLE</i>
Crankcase material <i>Matériel du carter</i>	Aluminium	
Piston material <i>Matériel du piston</i>	Aluminium	
Piston rings material <i>Matériel des segments</i>	Iron <i>Fonte</i>	
Exhaust muffler material <i>Matériel du pot d'échappement</i>	Sheet-steel <i>Tôle acier</i>	
Ball-bearings <i>Roulements</i>	6204 type	

### CRANKSHAFT - VILEBREQUIN

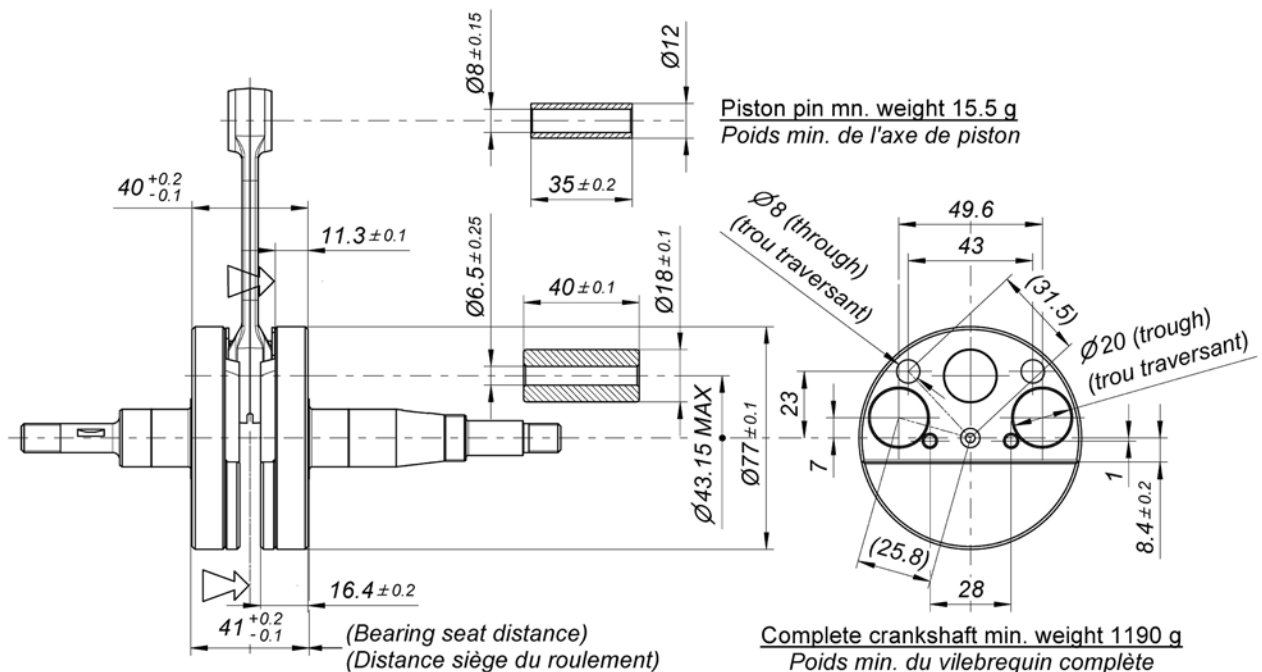

# CYLINDER DEVELOPMENT – DEVELOPPEMENT DU CYLINDRE

TOOL IAME Cod. 10194

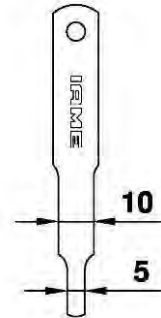
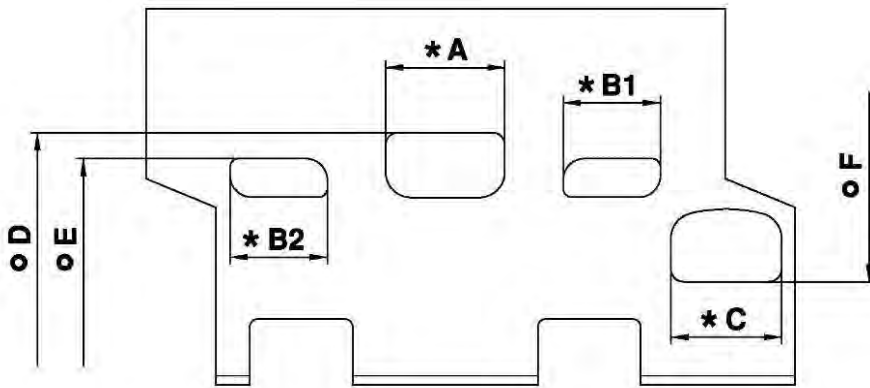

A	$\leq 28.5$ mm
B1 = B2	$\leq 22.3$ mm
C	$\leq 26.5$ mm
D	$155.5^\circ \pm 2^\circ$
E	$115.5^\circ \pm 2^\circ$
F	$143.0^\circ \pm 2^\circ$

\* CHORDAL READING – LECTURE CORDALE

o ANGULAR READING BY INSERT A 0.2x5 mm GAUGE –  
LECTURE ANGULAIRE PAR INSERTION D'UNE CALE DE 0.2x5 mm

USING IAME TOOL Cod. 10194 – UTILISER OUTIL

## CYLINDER BASE VIEW VUE DE LA BASE DU CYLINDRE

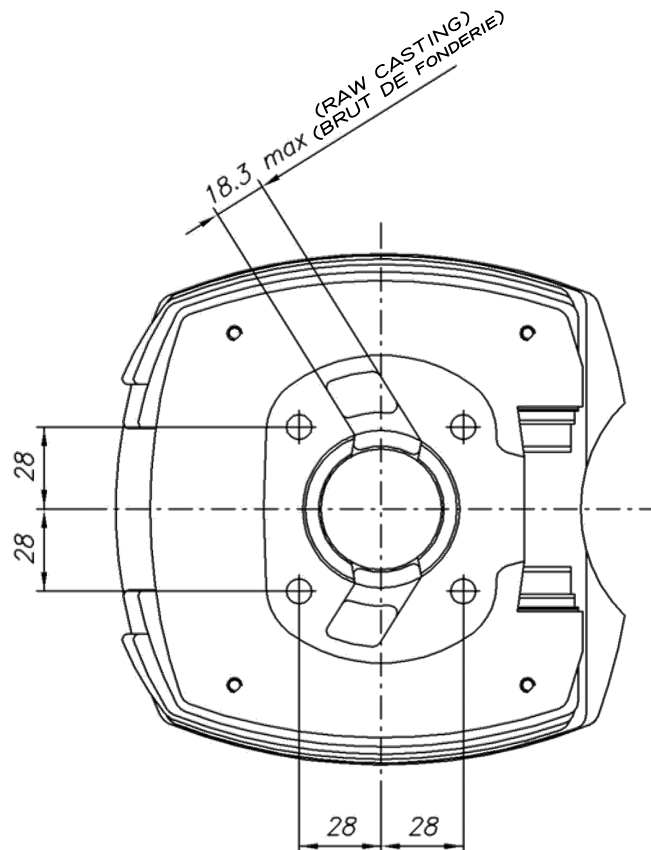

CYLINDER SECTION VIEW  
VUE EN SECTION DU CYLINDRE

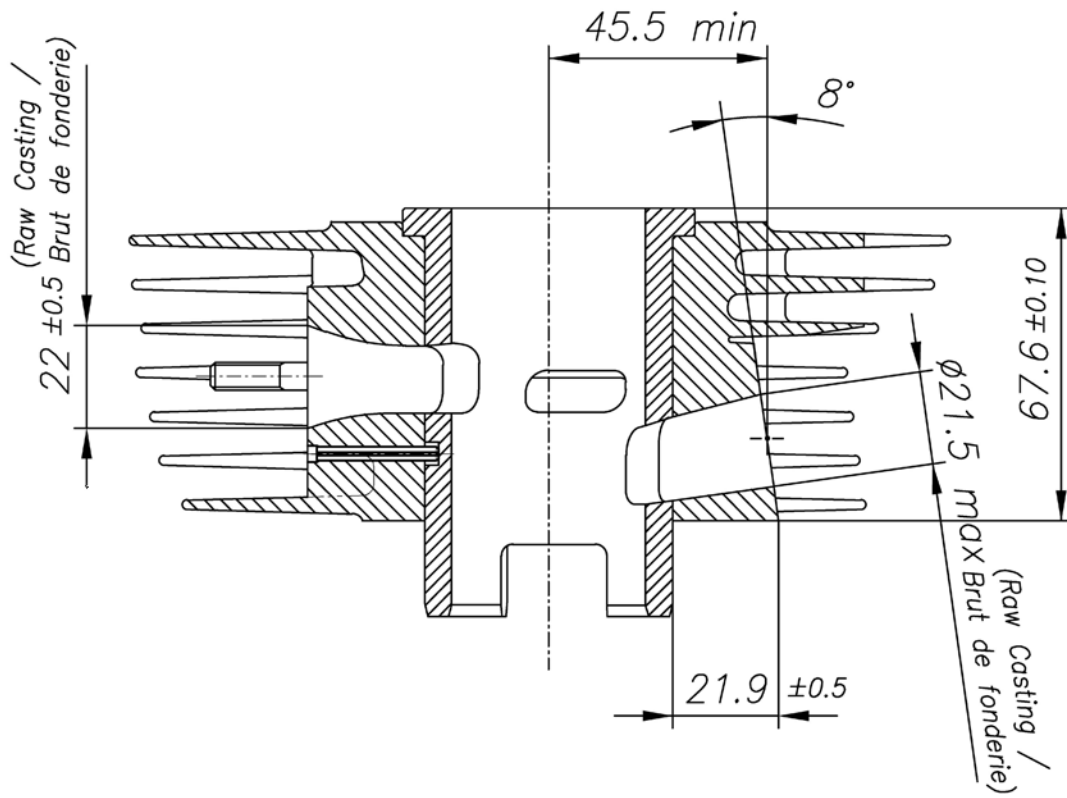

EXHAUST EXIT VIEW AND DIMENSION  
VEU ET DIMENSIONS DU SORTIE D'ECHAPPEMENT

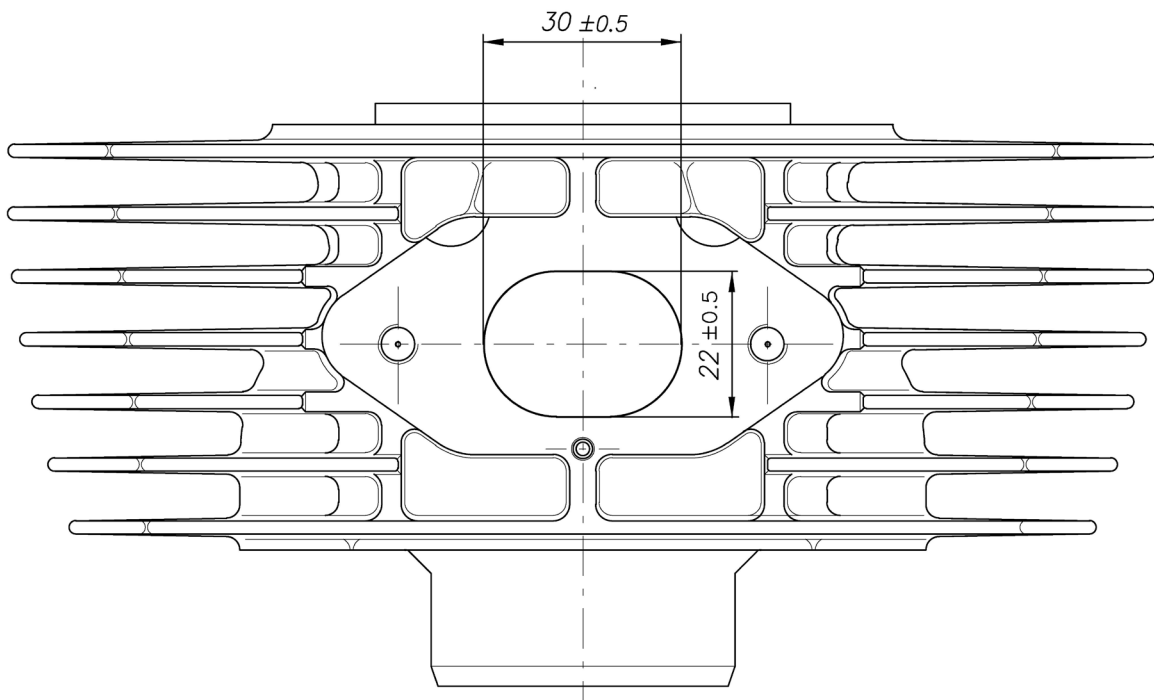

COMBUSTION CHAMBER VIEW  
 VUE DE LA CHAMBRE DE COMPRESSION

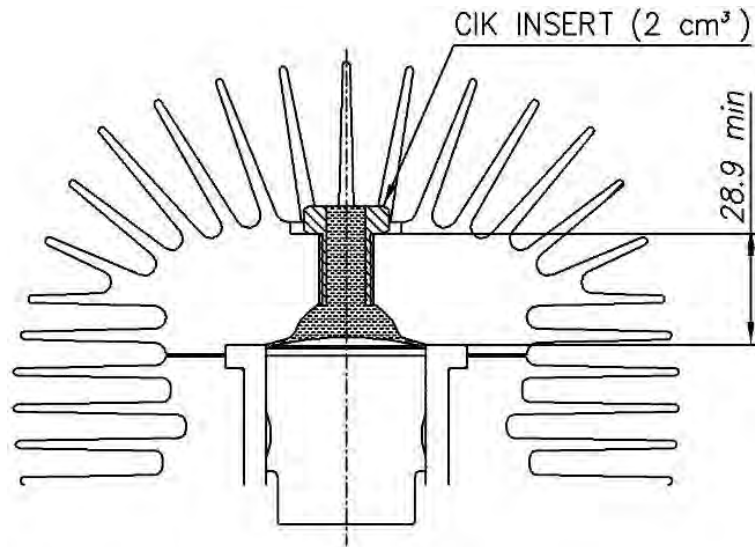

**COMBUSTION CHAMBER VOLUME = 6.5 cm<sup>3</sup> min.**  
**VOLUME CHAMBRE COMBUSTION**

VENTURI CARB. DIMENSIONS AND THERMAL SPACERS  
 DIMENSIONS DU VENTURI DU CARBURATEUR ET ESPACEURS THERMIQUE

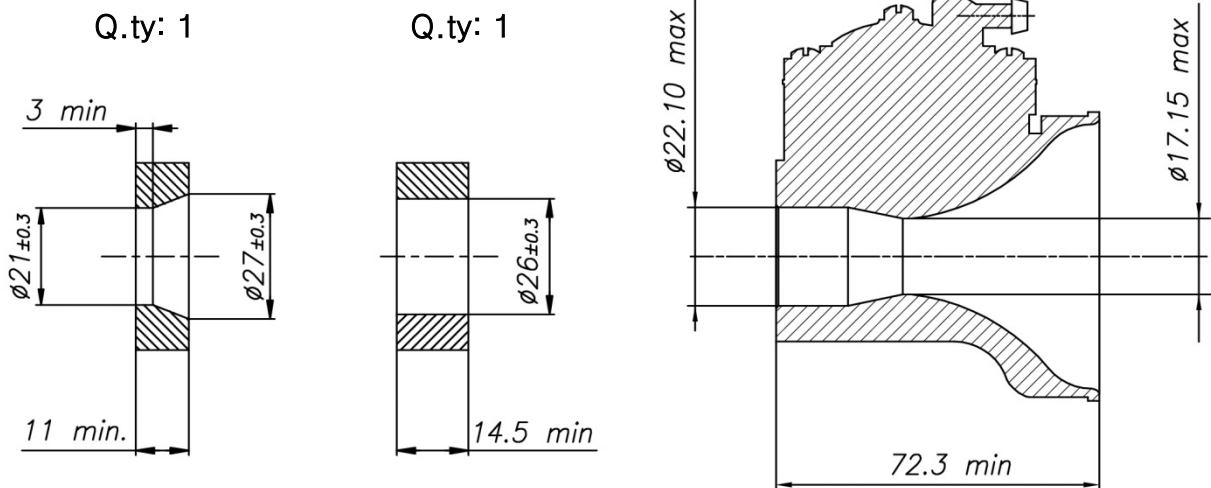

**TILLOTSON MOD. HW-31A**

CRANKCASE INSIDE VIEW  
VUE A' L'INTERIEUR DU CARTER

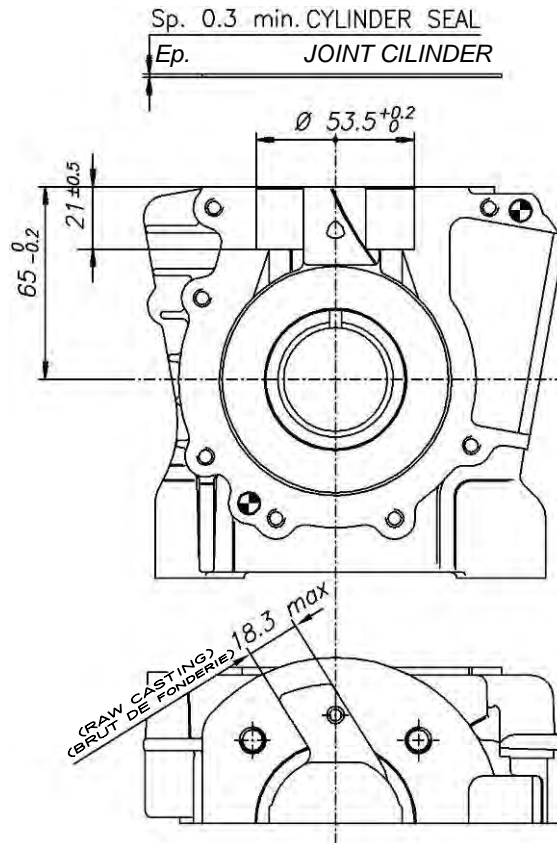

**FROM 2026 ON - A PARTIR DE 2026**

CRANKCASE UPPER VIEW – STICKER APPLICATION AREA  
CARTER – ZONE D'APPLICATION DE ADHÉSIF

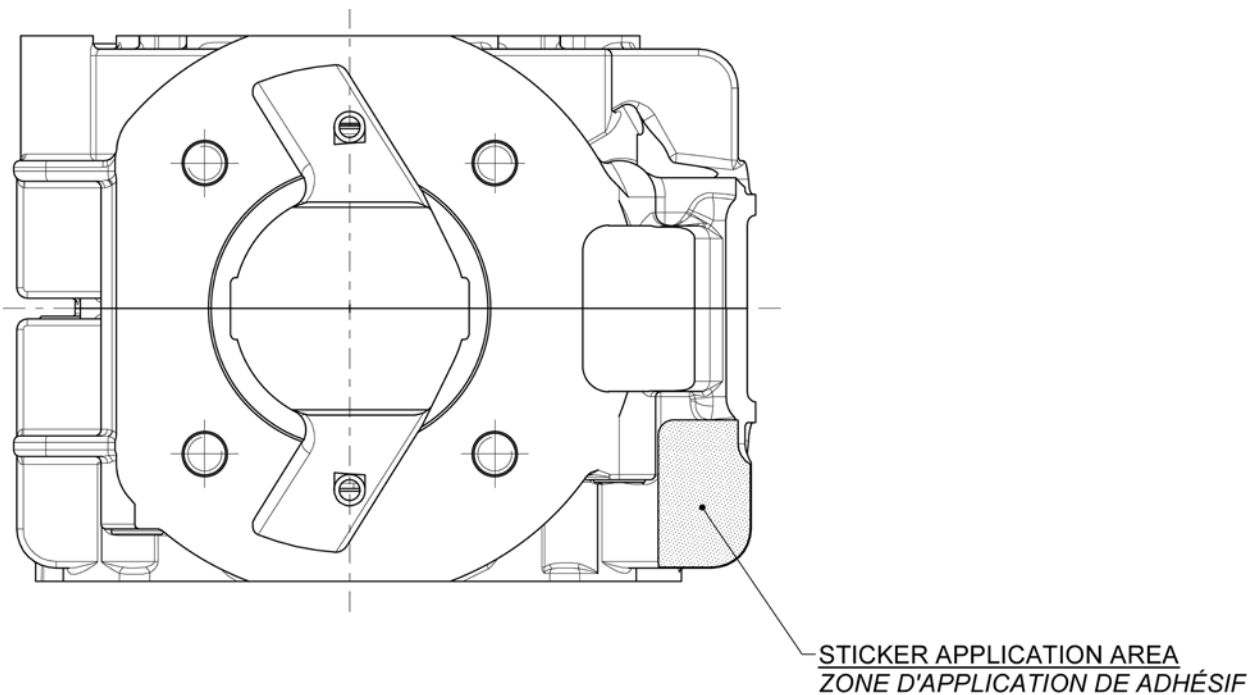

INLET SILENCER  
SILENCIEUX D'ASPIRATION

**(CSAI OMOLOGATION N° 01/SA/14)**

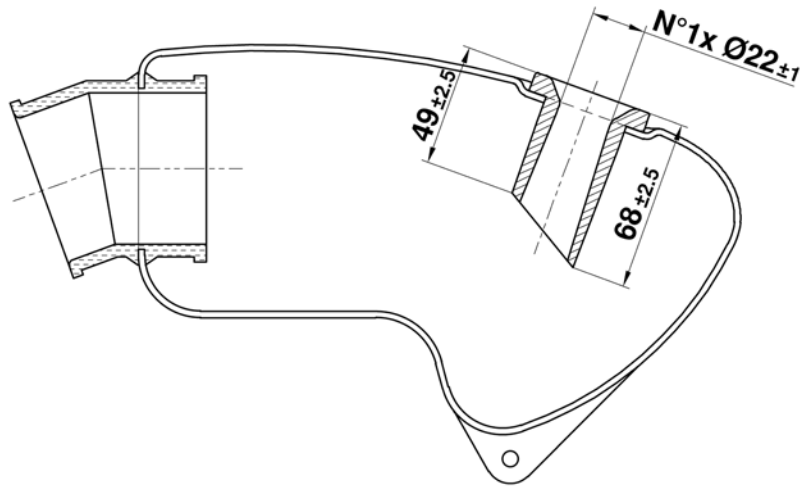

ALTERNATIVE INLET SILENCER  
ALTERNATIVE SILENCIEUX D'ASPIRATION

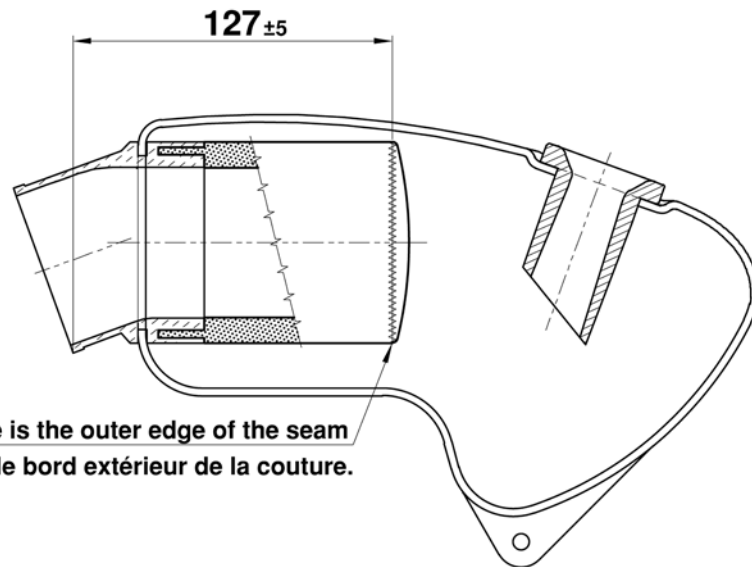

Reference is the outer edge of the seam  
La référence est le bord extérieur de la couture.

INLET SILENCER - PHOTO  
PHOTO - SILENCIEUX D'ASPIRATION



DESCRIPTION OF THE CLUTCH  
DESCRIPTION DE L'EMBRAYAGE

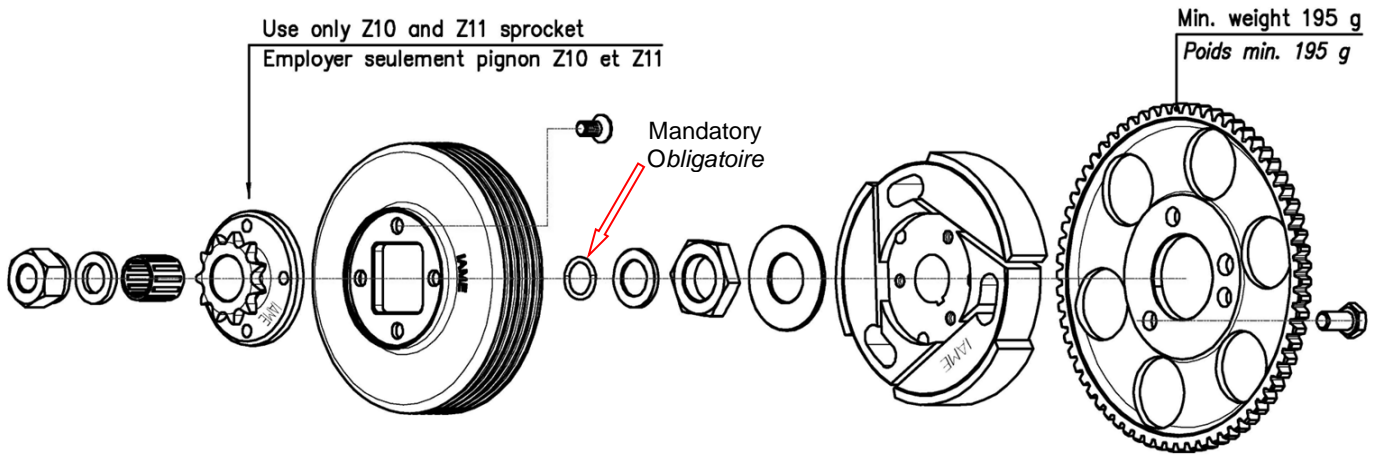

CLUTCH DRUM AND CLUTCH HUB DRAWING  
DESSIN DE LA CLOCHE D'EMBRAYAGE ET CORPS D'EMBRAYAGE

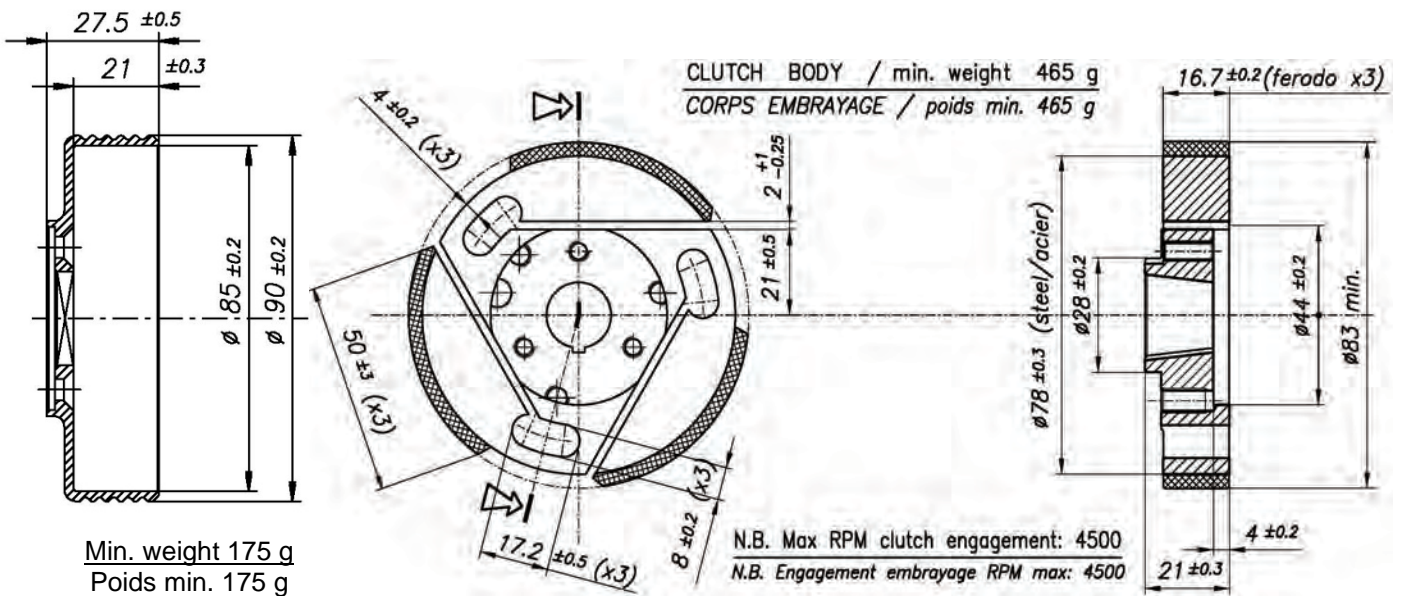

EXHAUST VIEW AND DIMENSIONS  
VUE ET DIMENSIONS DE L'ÉCHAPPEMENT

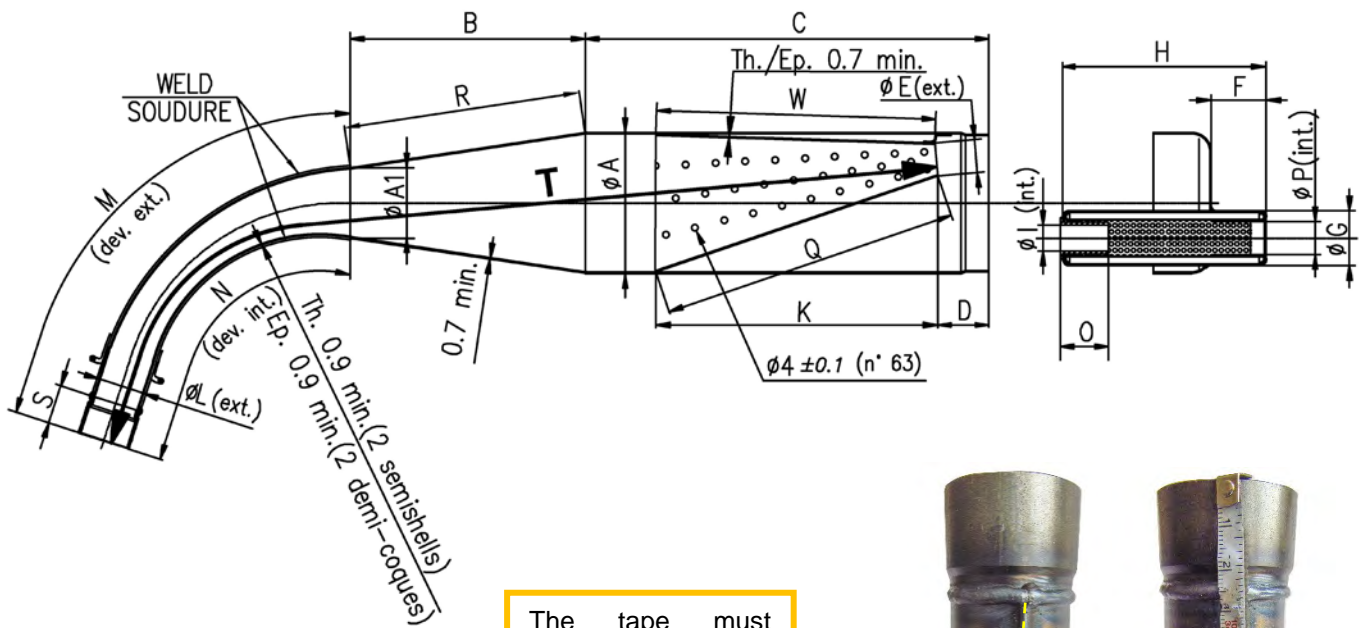

The tape must follow the centerline of the weld at all points  
Le ruban doit suivre l'axe de la soudure en tous points

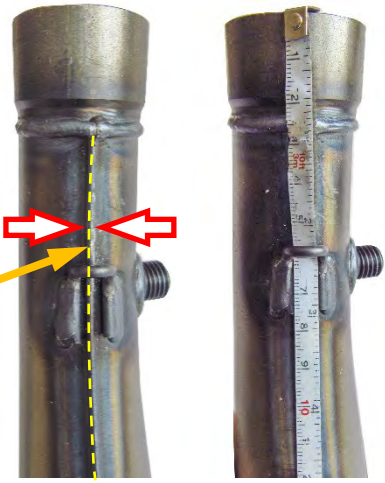

Min. weight 1.250 g  
Poids min.

<b>ØA:</b> 90 ±1.5 Øext.	<b>D:</b> 30 ±2	<b>H:</b> 132 ±2	<b>M:</b> 265 ±3	<b>R:</b> 152 ±3	<b>T:</b> 601 ±3
<b>ØA1:</b> 45 ±1 Øext.	<b>ØE:</b> 20 ±1 Øext.	<b>ØI:</b> 17 max Øint.	<b>N:</b> 215 ±3	<b>S:</b> 25 ±1	
<b>B:</b> 150 ±3	<b>F:</b> 35 ±2	<b>K:</b> 181 ±3	<b>O:</b> 30 min.	<b>Q:</b> 192 ±3	
<b>C:</b> 260 ±3	<b>ØG:</b> 35 ±1 Øext.	<b>ØL:</b> 31 ±1.5 Øext.	<b>ØP:</b> 21 ±1 Øint.	<b>W:</b> 181 ±3	

**ATTENTION:**

The dimensions "M", "N" and "T" must be taken by steel tape measure 6mm wide.  
*Les dimensions « M », « N » et « T » doivent être à l'aide d'un ruban à mesurer en acier 6 mm de large.*

The dimensions "M" and "N" must be taken on the weld centerline.  
*Les dimensions « M », « N » doivent être prises sur l'axe de la soudure.*

The dimensions "Q" and "W" must be taken by steel tape measure 12mm wide.  
*Les dimensions « Q » et « W » doivent être prises à l'aide d'un ruban à mesurer en acier 12 mm de large.*

EXHAUST IDENTIFICATION PHOTO  
PHOTO D'IDENTIFICATION D'ECHAPPEMENT



MARKING / MARQUAGE

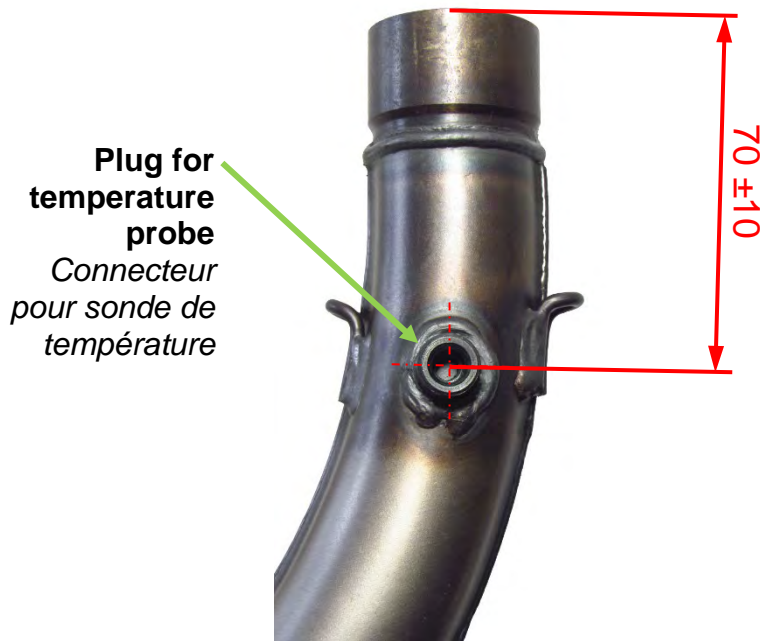

EXHAUST FITTING TYPES  
RACCORD D'ÉCHAPPEMENT

Unrestricted



Restricted Ø18 MAX



WIRING DIAGRAM  
SCHEMA CIRCUIT ELECTRIQUE

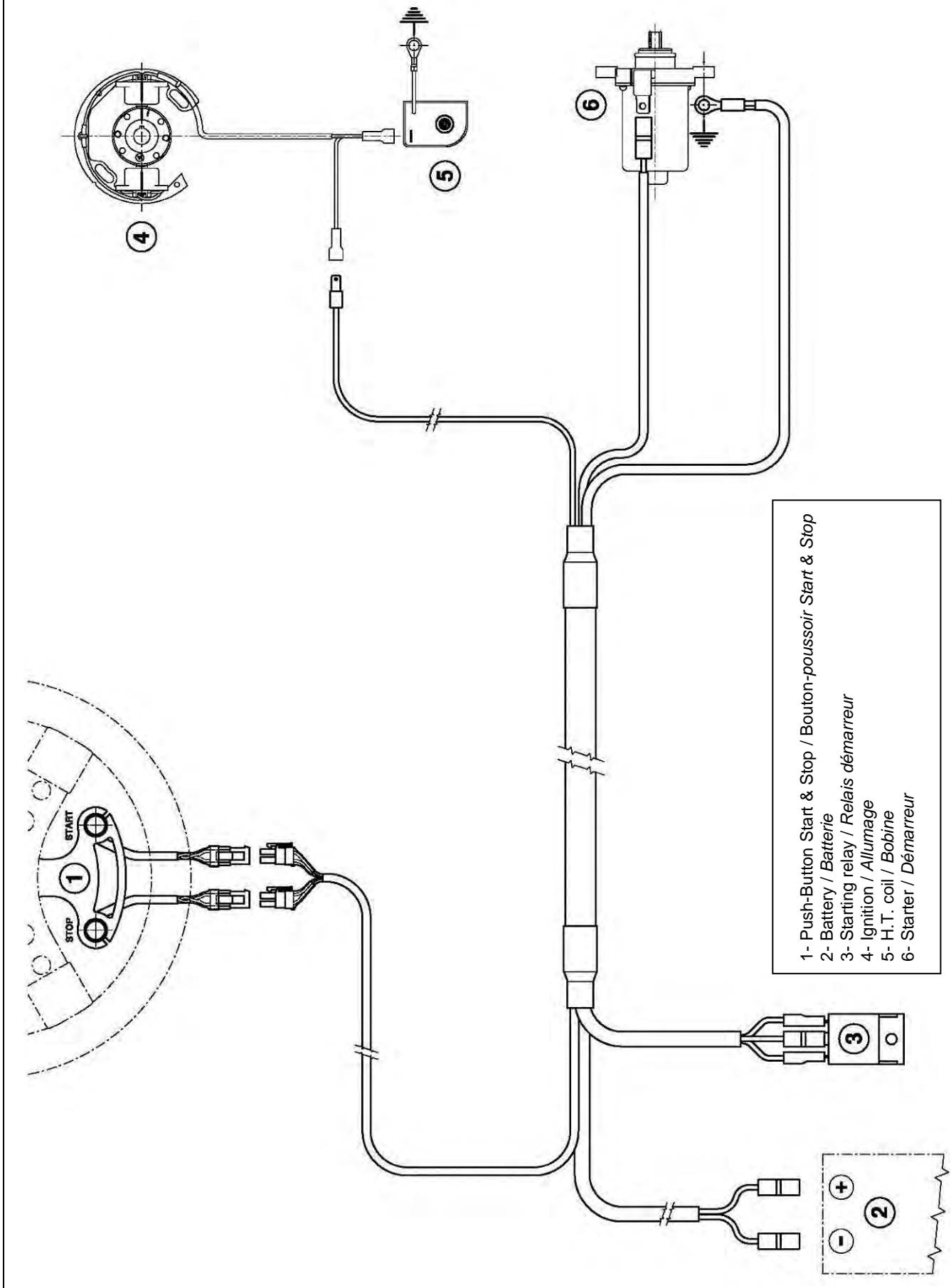

PHOTO COMPLETE WIRING  
PHOTO DU CÂBLAGE ÉLECTRIQUE COMPLÈTE

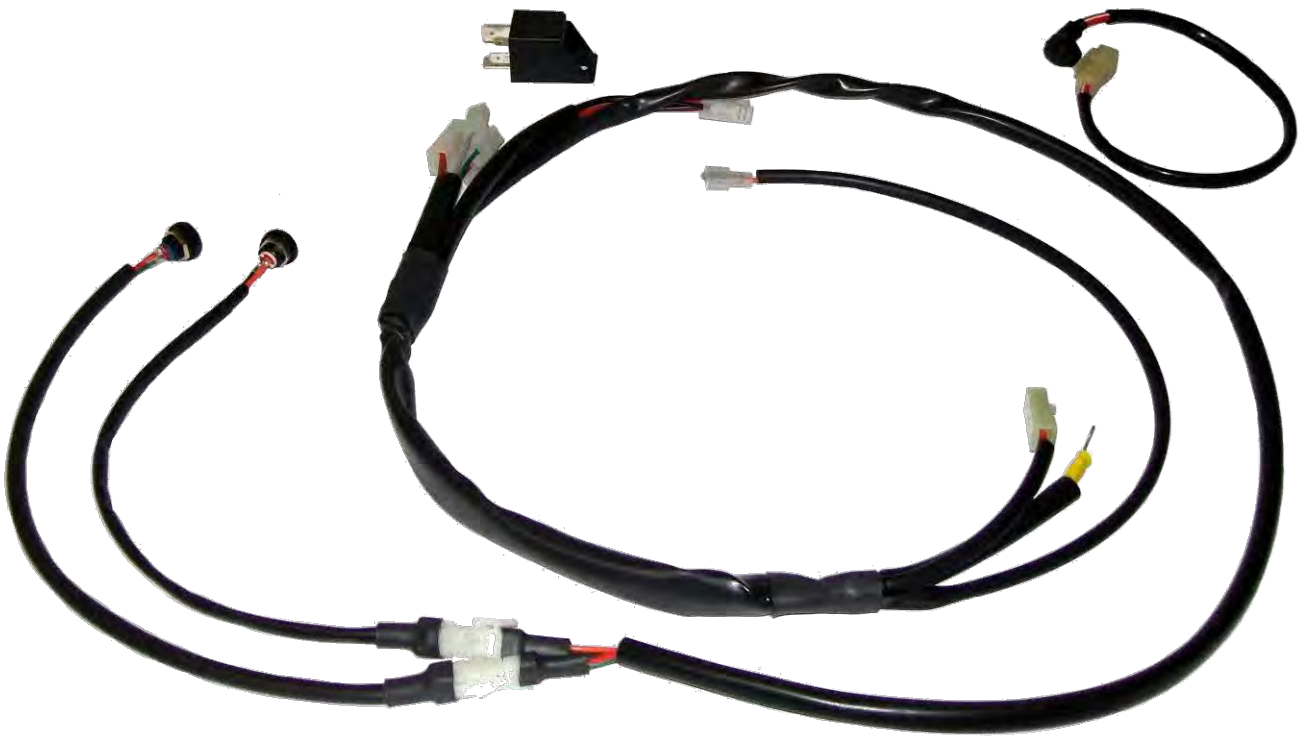
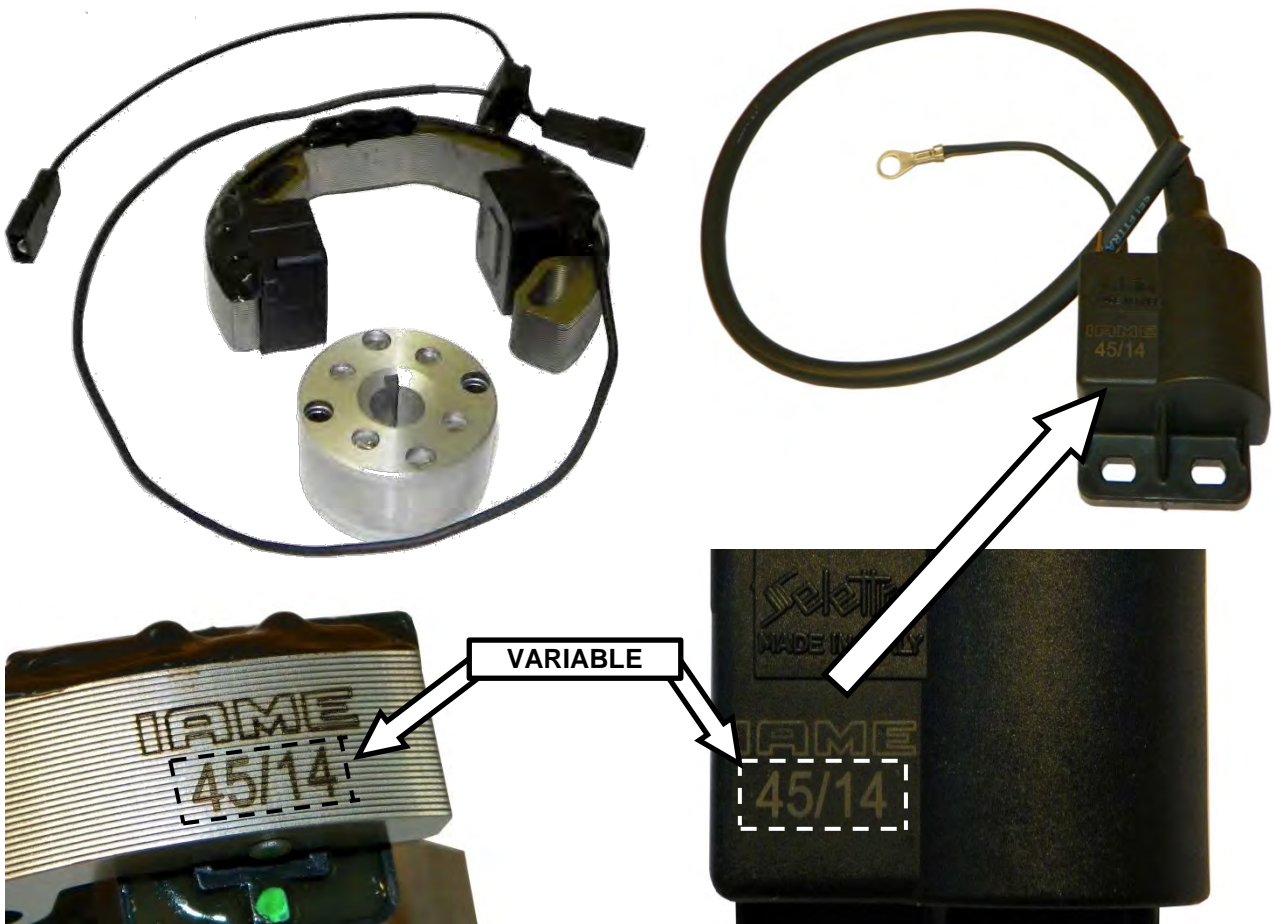

PHOTO OF IGNITION / PHOTO OF H.T. COIL (SELETTA ANALOGUE 2 POLES)  
PHOTO DU ALLUMAGE ET BOBINE



ALTERNATIVE WIRING LOOM DIAGRAM  
 SCHÉMA CIRCUIT ÉLECTRIQUE ALTERNATIF

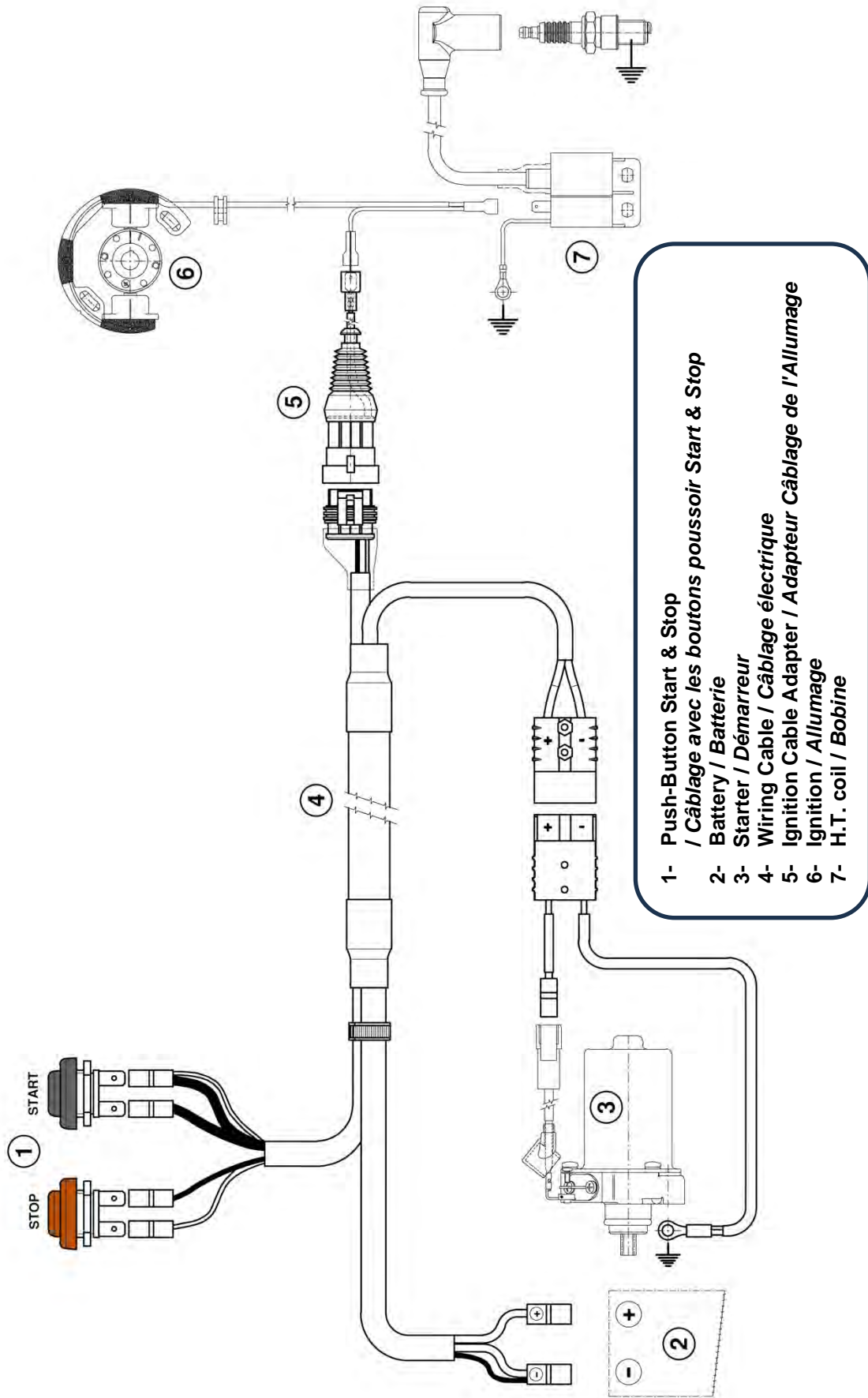
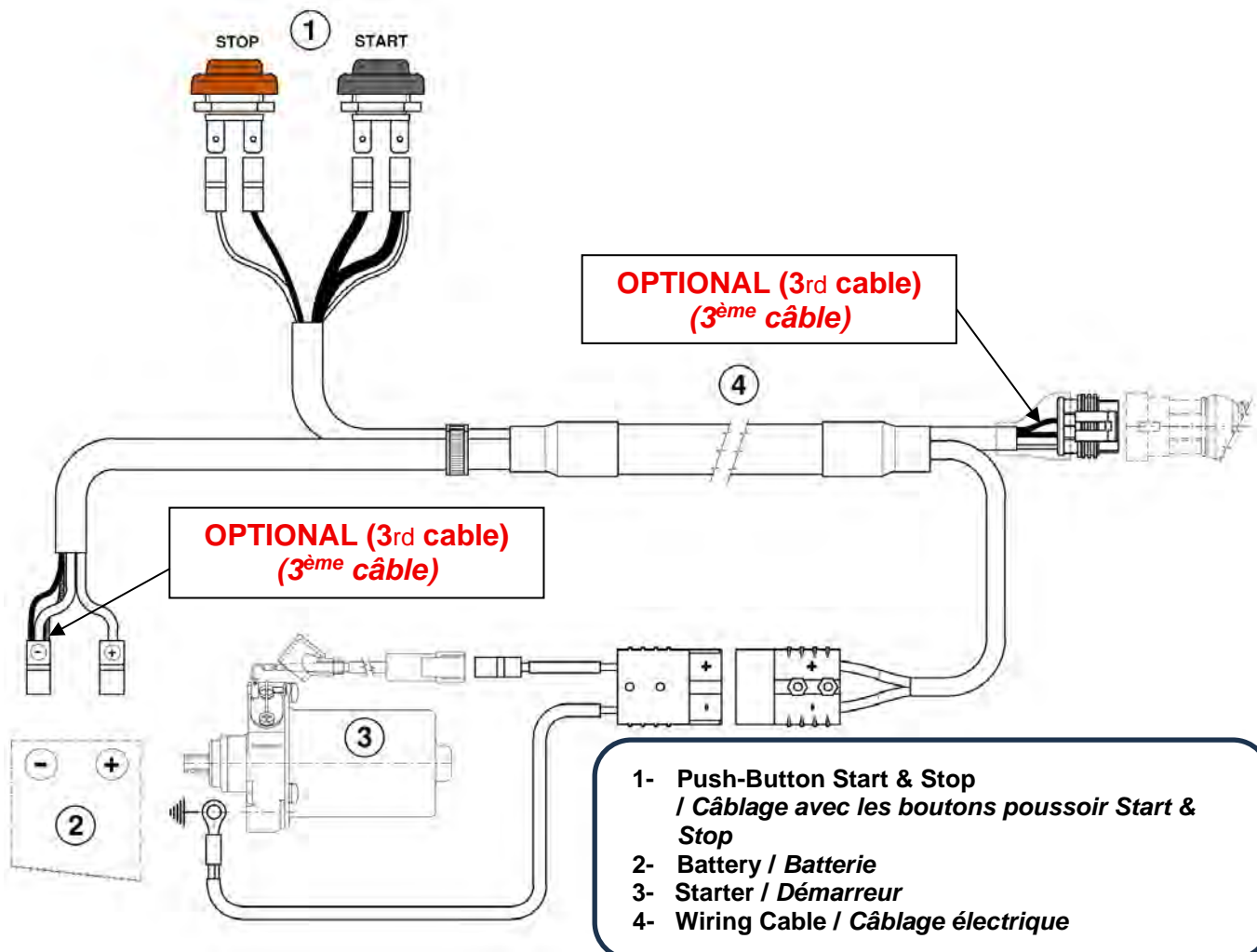

PHOTO OF ALTERNATIVE COMPLETE WIRING LOOM  
 PHOTO DU CÂBLAGE ÉLECTRIQUE COMPLÈTE ALTERNATIF



ALTERNATIVE WIRING LOOM DIAGRAM / CÂBLAGE ÉLECTRIQUE ALTERNATIF



IDENTIFICATION OF PISTON IT1 TYPES  
 IDENTIFICATION DE LES TYPES DU PISTON IT1  
 (Dimensions and weight are the same for both types /  
 les dimensions et le poids sont les mêmes pour les deux types)

CURRENT / COURANT

ALTERNATIVE / ALTERNATIF

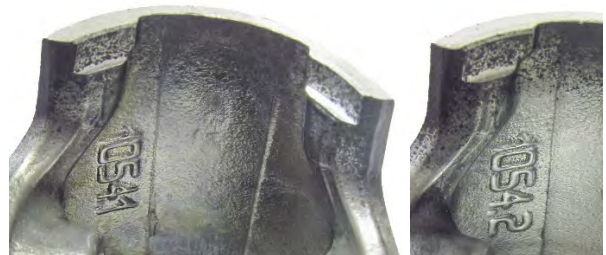
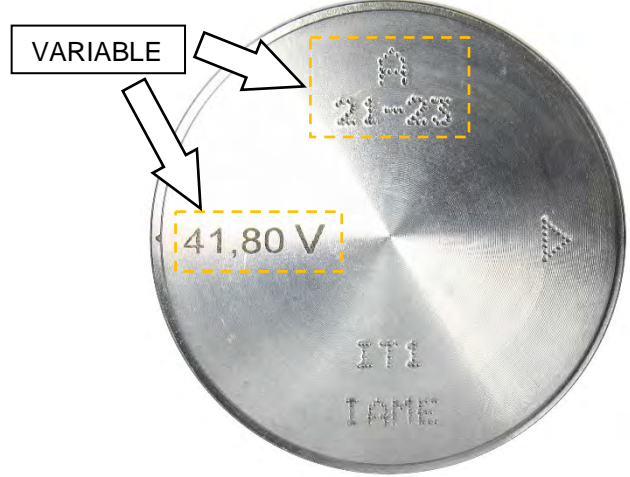
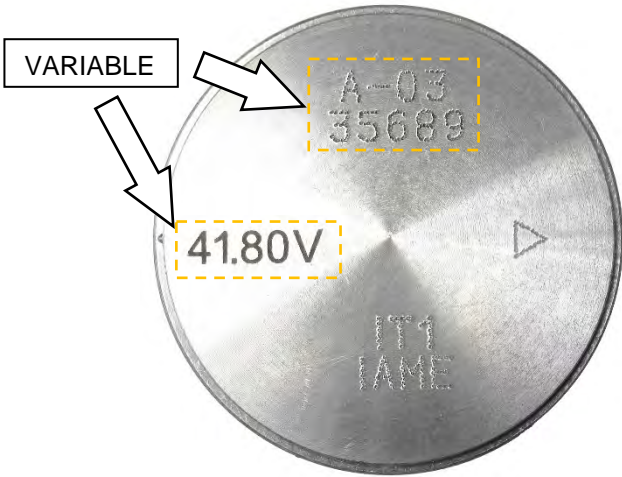

CYLINDER IDENTIFICATION MARKING  
MARQUAGE D'IDENTIFICATION DU CYLINDRE

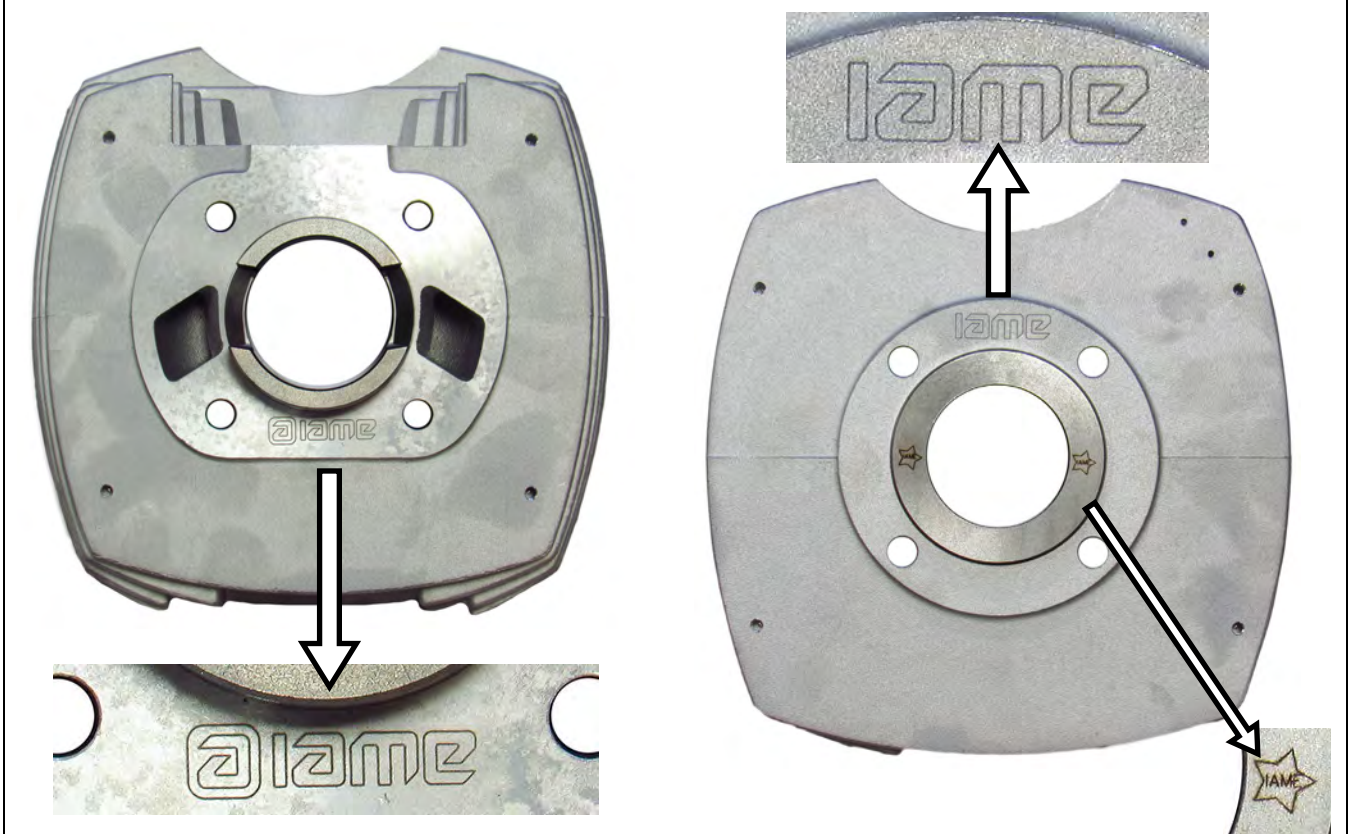

HEAD IDENTIFICATION MARKING  
MARQUAGE D'IDENTIFICATION DE LA CULASSE



**FROM 2025 ON - A PARTIR DE 2025**

CYLINDER IDENTIFICATION – ALTERNATIVE CYLINDER LINER LOCK PIN  
*IDENTIFICATION DU CYLINDRE – GOUPILLE DE BLOCAGE DE LA ACHEMISE ALTERNATIF*

CURRENT PIN (SPRING PIN)  
*GOUPILLE COURANTE (GOUPILLE À RESORT)*

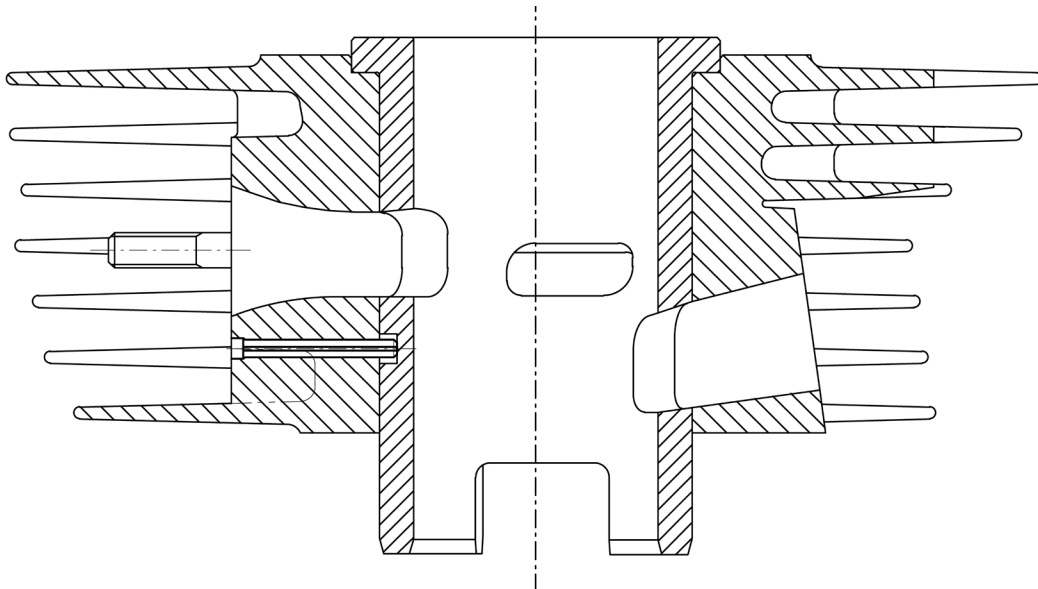

ALTERNATIVE PIN (GROOVED PIN)  
*GOUPILLE ALTERNATIF - (GOUPILLE CANNELÉE)*

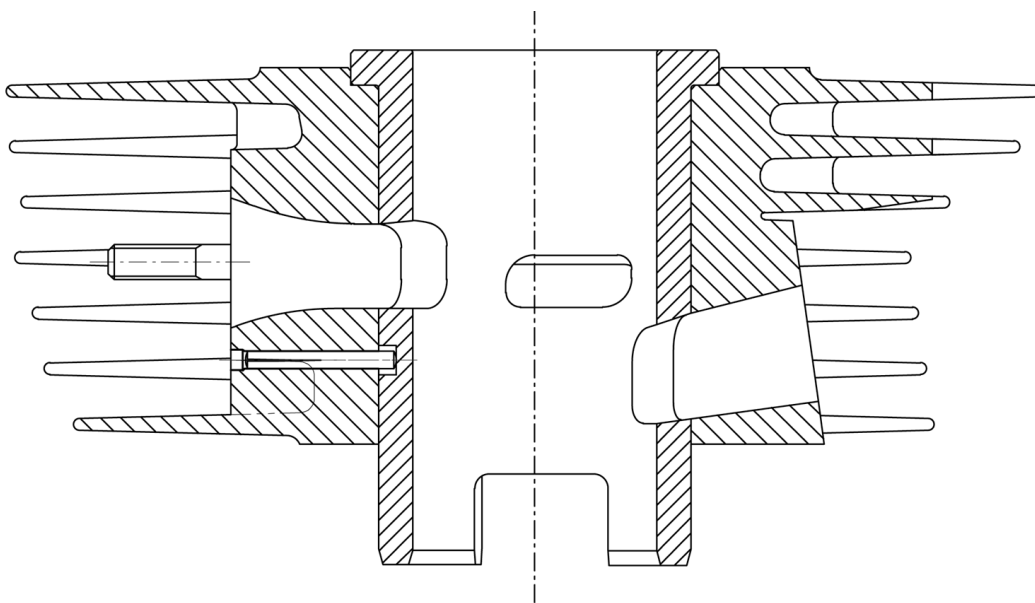

**FROM 2025 ON - A PARTIR DE 2025**

**CYLINDER IDENTIFICATION – ALTERNATIVE CYLINDER LINER LOCK PIN  
IDENTIFICATION DU CYLINDRE – GOUPILLE DE BLOCAGE DE LA CHEMISE ALTERNATIF**

**CURRENT PIN  
GOUPILLE COURANTE**

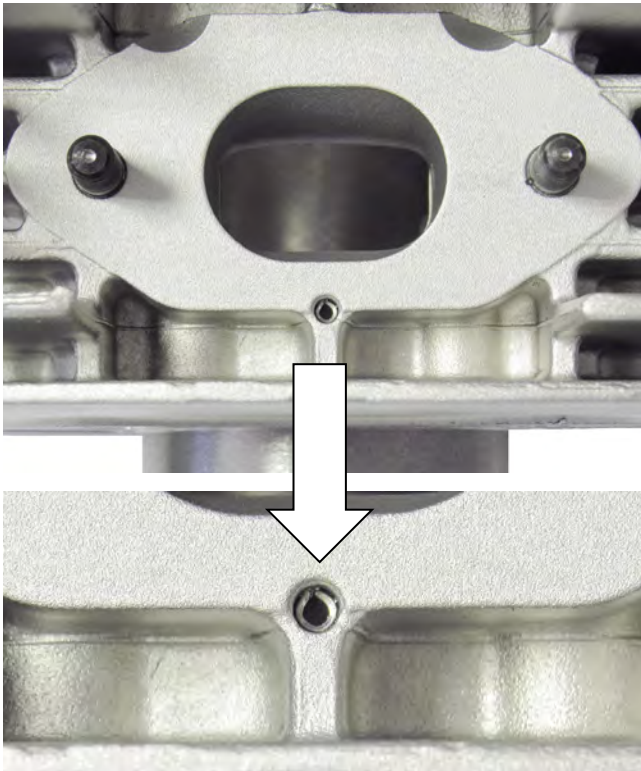

**SPRING PIN  
GOUPILLE À RESORT**

**ALTERNATIVE PIN  
GOUPILLE ALTERNATIF**

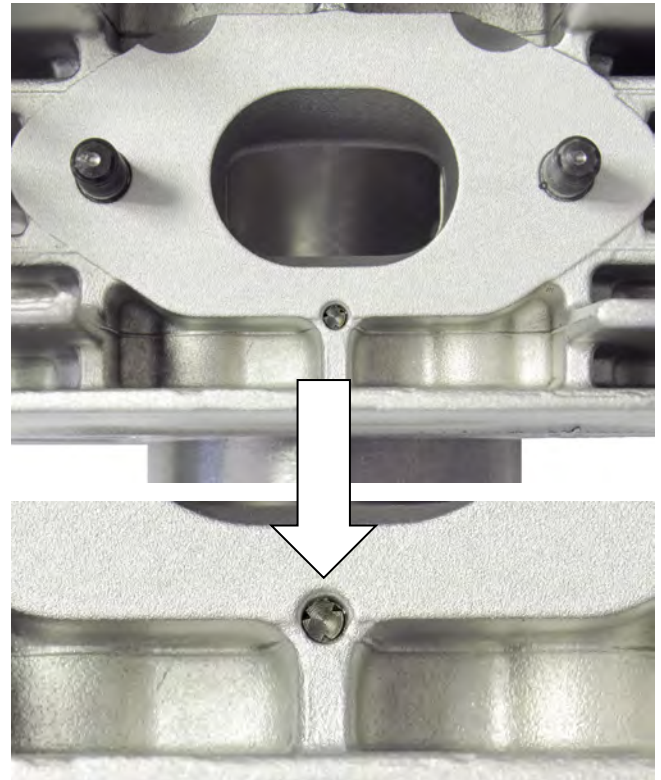

**GROOVED PIN  
GOUPILLE CANNELÉE**

SEMICARTER IGNITION SIDE AND TRANSMISSION SIDE IDENTIFICATION MARKING  
MARQUAGE D'IDENTIFICATION DU SEMICARTER CÔTÉ ALLUMAGE ET PIGNON

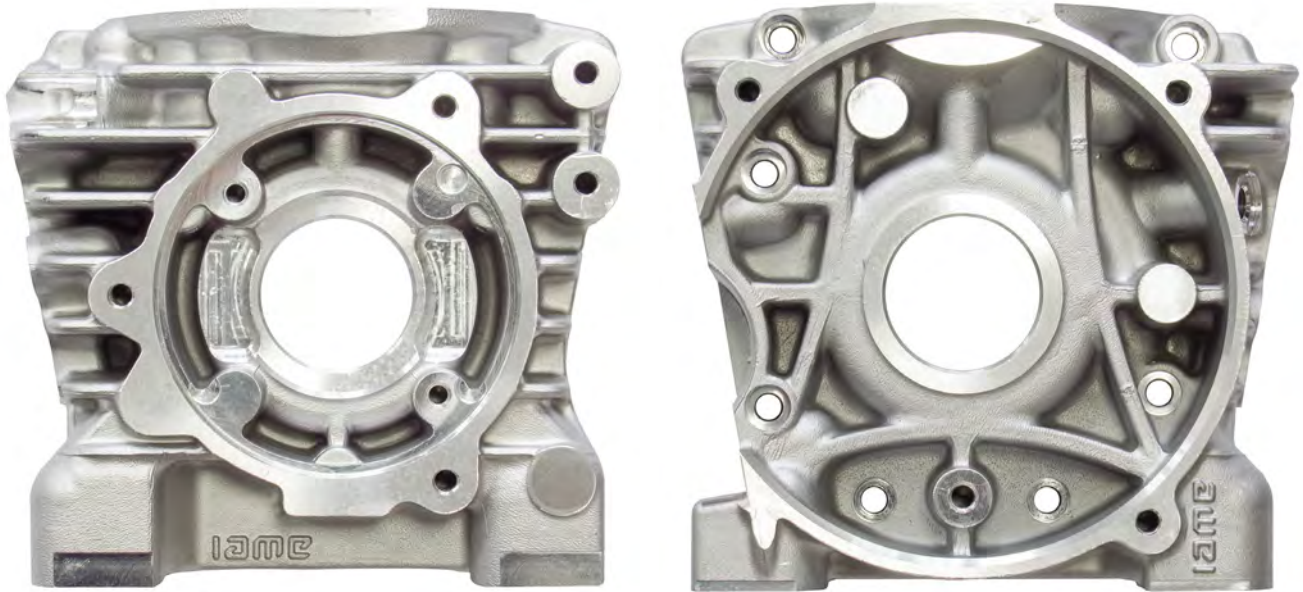

STARTER RING IDENTIFICATION MARKING  
MARQUAGE D'IDENTIFICATION DE LA COURONNE DE DEMARRAGE



CRANKSHAFT PHOTOS  
*PHOTO D'IDENTIFICATION DU VILEBREQUIN*

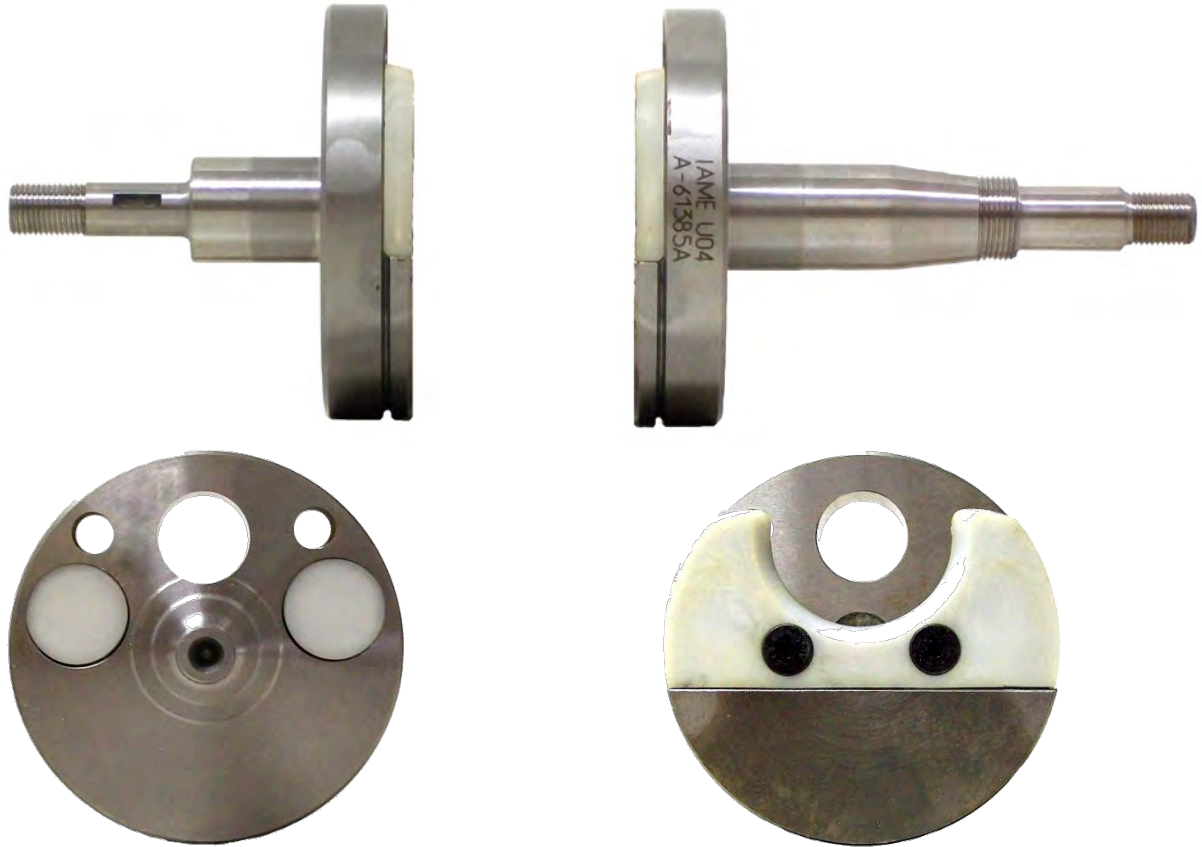
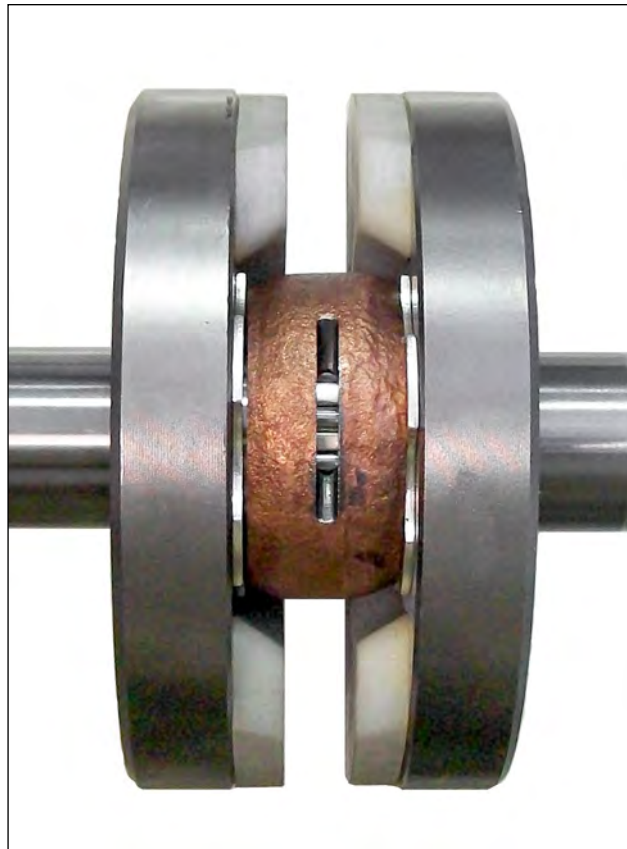
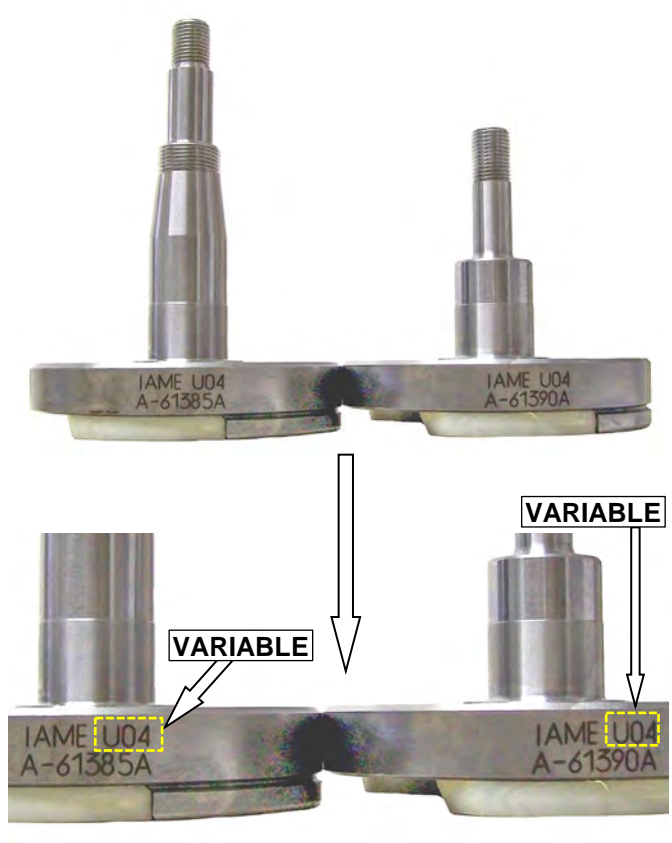

PHOTO OF COMPLETE CRANKSHAFT  
*PHOTO DU VILEBREQUIN COMPLETE*



**CRANKSHAFT IDENTIFICATION MARKINGS**  
**MARQUAGE D'IDENTIFICATION DU**  
**VILEBREQUIN**



**CONROD IDENTIFICATION MARKINGS**  
**MARQUAGE D'IDENTIFICATION BIELLE**

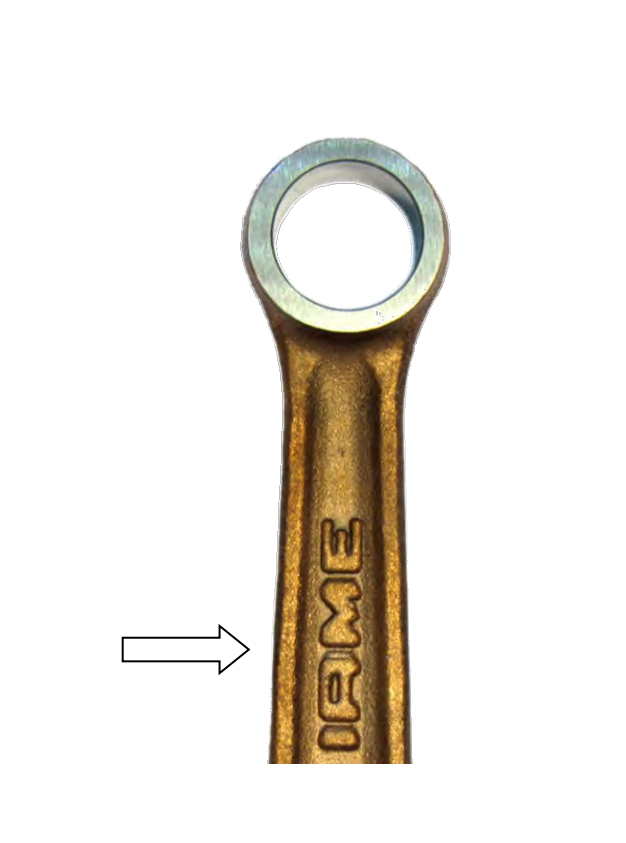

**CLUTCH HUB IDENTIFICATION MARKING**  
**MARQUAGE D'IDENTIFICATION CORPS DE**  
**EMBRAYAGE**



**CLUTCH DRUM IDENTIFICATION MARKING**  
**MARQUAGE D'IDENTIFICATION DE LA**  
**CALOTTE**



IGNITION COVER IDENTIFICATION MARKING  
MARQUAGE D'IDENTIFICATION  
COUVERCLE DU ALLUMAGE

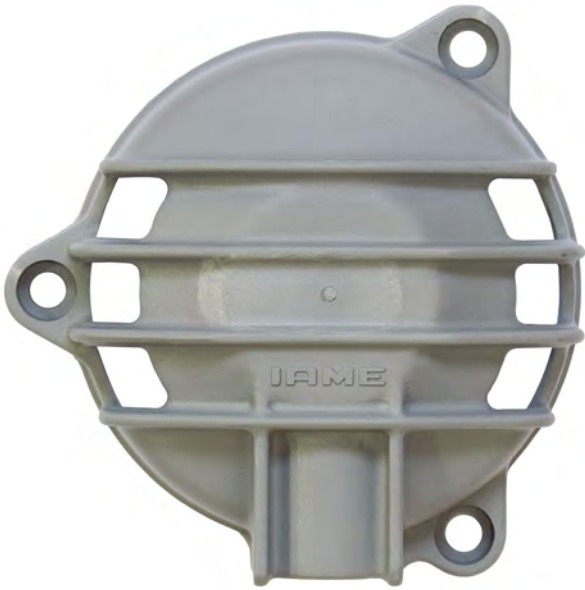

**ALTERNATIVE NEW LOGO**



CLUTCH COVER IDENTIFICATION MARKING  
MARQUAGE D'IDENTIFICATION  
COUVERCLE D'EMBRAYAGE



INLET FILTER IDENTIFICATION MARKING  
MARQUAGE D'IDENTIFICATION SILENCIEUX D'ASPIRATION



PHOTO IDENTIFICATION OF CONROD – ALTERNATIVE TYPES  
PHOTO D'IDENTIFICATION DE LA BIELLE – TYPES ALTERNATIFS

TYPE 1



TYPE 2



TYPE 3



PARTICULARS WITH ALTERNATIVE NEW LOGO "IAME"  
PARTICULARITÉS AVEC UN NOUVEAU LOGO ALTERNATIF «IAME»

**THE OTHERS COMPONENTS OF ENGINE THAT ARE MARKED  
(LASER OR PUNCHING) UNTIL TODAY WITH LOGO OR WRITTEN "IAME"**  
**LES AUTRES COMPOSANTS DU MOTEUR AVEC MARQUAGE (LASER OU  
POINÇONNEUSE) AUJOURD'HUI AVEC LE LOGO OU ÉCRIT «IAME»**

I A M E

or

**IAME**

**NOW COULD BE MARKED WITH NEW LOGO "IAME"**  
**MAINTENANT POURRAIT EST MARQUAGE AVEC UN NOUVEAU LOGO**  
**"IAME"**

IAME

or

IAME

or

IAME



**CARBURETTOR / CARBURATEUR**  
**Tillotson HW-31A**



PHOTO OF ADJUSTING SIDE  
 PHOTO CÔTÉ RÉGLAGE

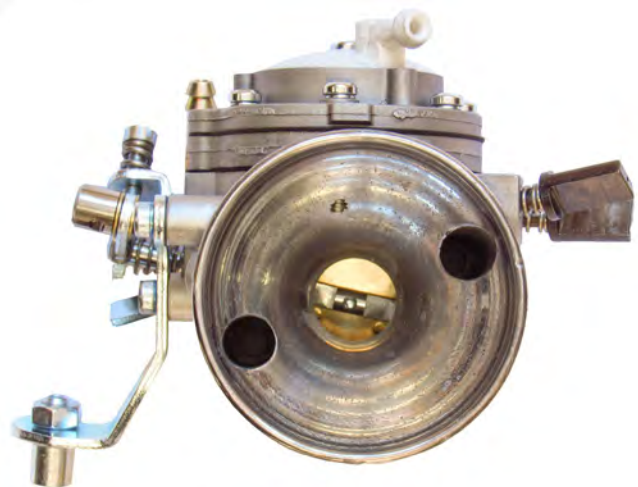
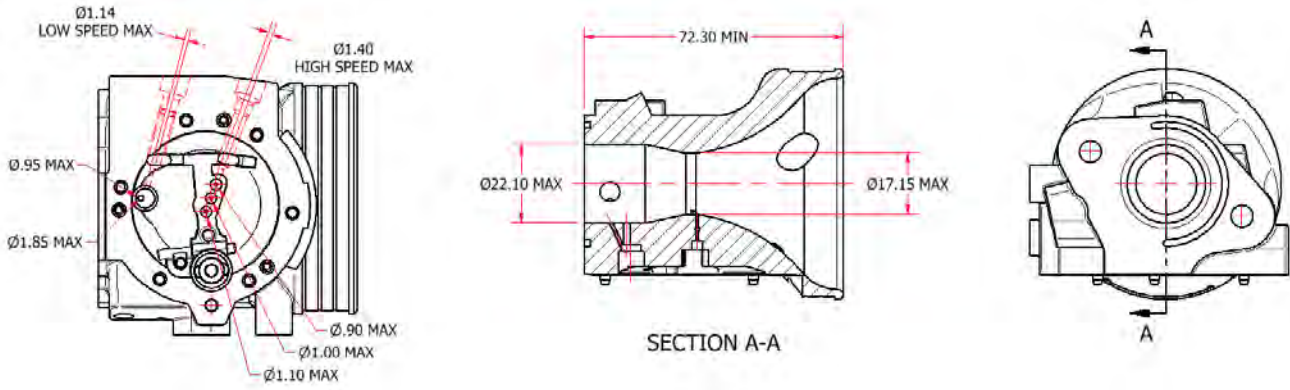

PHOTO OF INLET SIDE  
 PHOTO CÔTÉ ASPIRATION

Manufacturer - <i>Constructeur</i>	<b>TILLOTSON LTD.</b>
Make - <i>Marque</i>	<b>TILLOTSON</b>
Model - <i>Modèle</i>	<b>HW-31A</b>

SECTION VIEW – VUE DE SECTION AVEC DIMENSIONS



“IAME” MARKING – MARQUAGE “IAME”

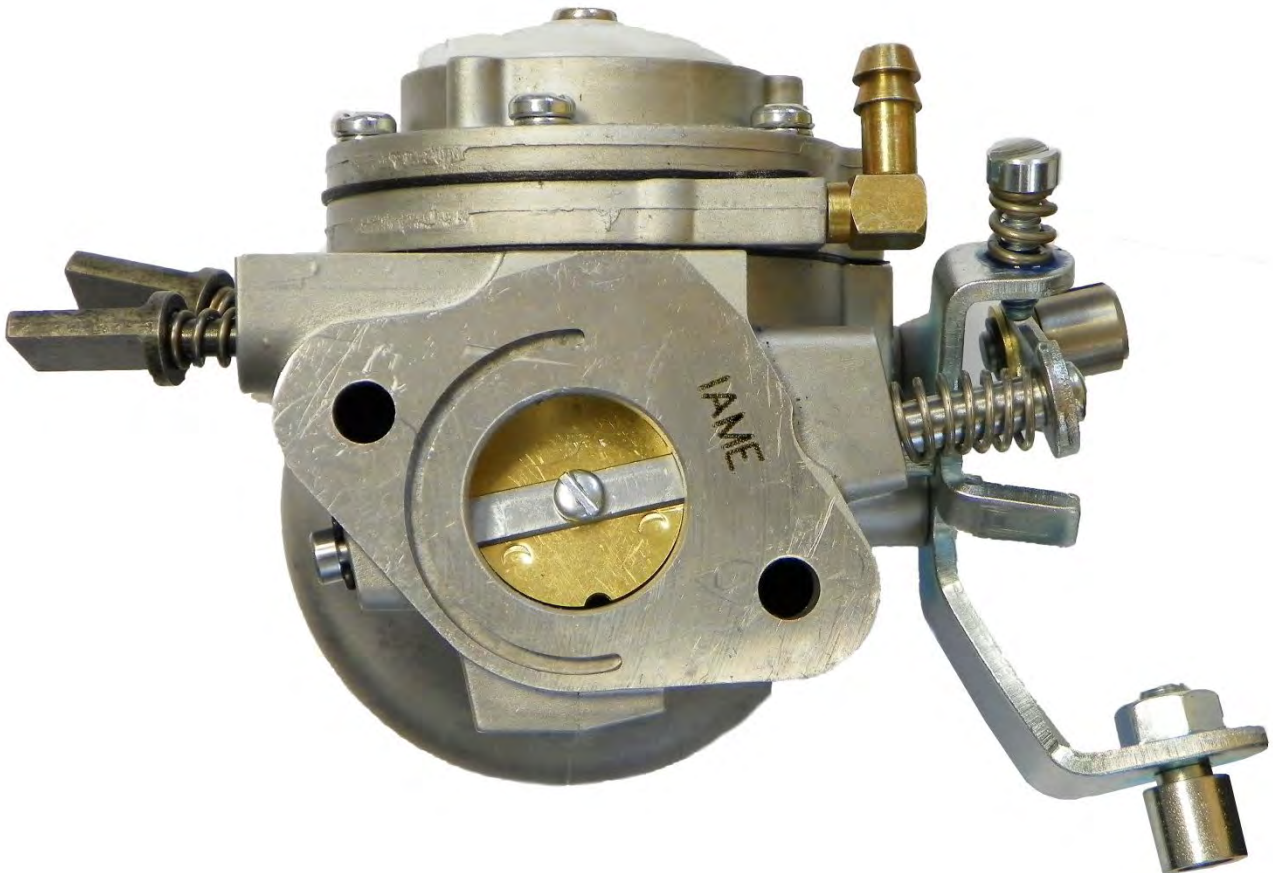

# CARBURETTOR - DESCRIPTION AND SKETCH OF PARTS CARBURATEUR - DESCRIPTION ET DESSIN DES PIÈCES

**HW-31A**

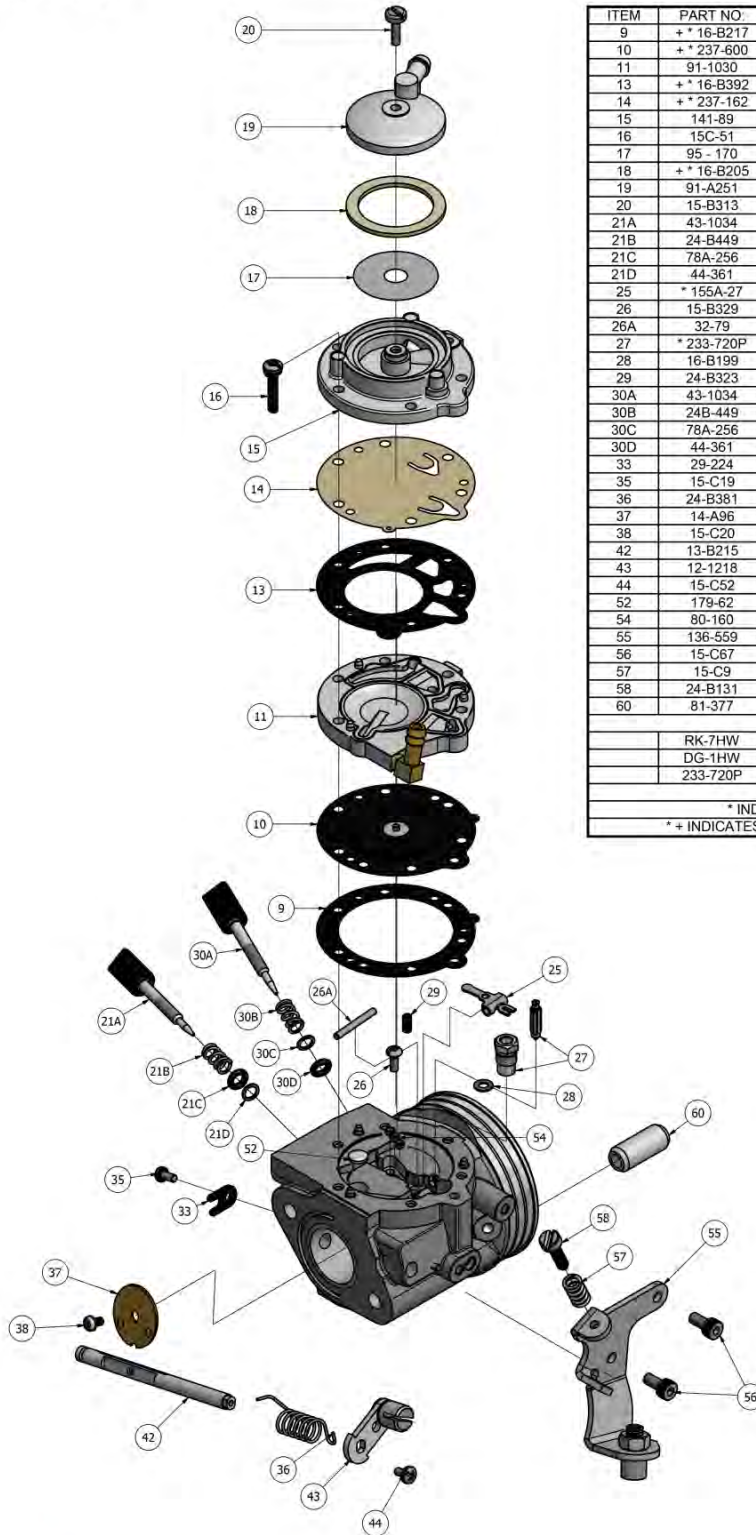

ITEM	PART NO.	DESCRIPTION	QTY
9	+ * 16-B217	DIAPHRAGM GASKET	1
10	+ * 237-600	DIAPHRAGM	1
11	91-1030	DIAPHRAGM COVER	1
13	+ * 16-B392	FUEL PUMP GASKET	1
14	+ * 237-162	FUEL PUMP DIAPHRAGM	1
15	141-89	FUEL PUMP BODY	1
16	15C-51	FUEL PUMP BODY SCREW	6
17	95 - 170	FUEL STRAINER SCREEN	1
18	+ * 16-B205	FUEL STRAINER COVER GASKET	1
19	91-A251	FUEL STRAINER COVER	1
20	15-B313	FUEL STRAINER COVER RETAINING SCREW	1
21A	43-1034	IDLE MIXTURE SCREW	1
21B	24-B449	IDLE MIXTURE SCREW SPRING	1
21C	78A-256	IDLE MIXTURE SCREW WASHER	1
21D	44-361	IDLE MIXTURE SCREW PACKING	1
25	* 155A-27	INLET CONTROL LEVER	1
26	15-B329	FULCRUM LEVER SCREW	1
26A	32-79	FULCRUM LEVER PIN	1
27	* 233-720P	INLET NEEDLE & SEAT SET	1
28	16-B199	INLET SEAT GASKET	1
29	24-B323	INLET TENSION SPRING	1
30A	43-1034	HIGH SPEED MIXTURE SCREW	1
30B	24B-449	HIGH SPEED MIXTURE SCREW SPRING	1
30C	78A-256	HIGH SPEED MIXTURE SCREW WASHER	1
30D	44-361	HIGH SPEED MIXTURE SCREW PACKING	1
33	29-224	THROTTLE SHAFT CLIP	1
35	15-C19	THROTTLE SHAFT CLIP RETAINING SCREW	1
36	24-B381	THROTTLE RETURN SPRING	1
37	14-A96	THROTTLE SHUTTER	1
38	15-C20	THROTTLE SHUTTER SCREW	1
42	13-B215	THROTTLE SHAFT	1
43	12-1218	THROTTLE LEVER ASSEMBLY	1
44	15-C52	THROTTLE LEVER RETAINING SCREW	1
52	179-62	WELCH PLUG	1
54	80-160	MAIN PLUG	3
55	136-559	CABLE BRACKET	1
56	15-C67	CABLE BRACKET RETAINING SCREW	2
57	15-C9	LIMITER SCREW	2
58	24-B131	LIMITER SPRING	2
60	81-377	CARBURETTOR MOUNTING NUT	2
	RK-7HW	REPAIR KIT	
	DG-1HW	DIAPHRAGM & GASKET (STANDARD)	
	233-720P	INLET NEEDLE & SEAT SET	
* INDICATES CONTENTS OF REPAIR KIT			
* + INDICATES CONTENTS OF DIAPHRAGM & GASKET SET			



Clash Industrial Estate - Tralee - Ireland  
www.tillotson-racing.com



PARTS OF CARBURETTOR – PIÈCES DU CARBURATEUR

REF.9 - P. N°16-B217  
DIAPHRAGM GASKET  
JOINT DE DIAPHRAGME



Thickness / *Epaisseur* = 0.5 ±0.1 mm

REF.13 - P. N° 16-B392  
PUMP DIAPHRAGM GASKET  
JOINT DE POMPE A ESSENCE



Thickness / *Epaisseur* = 0.8 ±0.1 mm

REF.10 - P. N°237-600  
DIAPHRAGM  
DIAPHRAGME ASSEMBLE



Thickness / *Epaisseur* = 0.13 ±0.07 mm

REF.14 - P. N°237-162  
PUMP DIAPHRAGM  
MEMBRANE DE POMPE A ESSENCE



Thickness / *Epaisseur* = 0.10 ±0.063 mm

REF.11 - P. N° 91-1031  
DIAPHRAGM COVER  
COUVERCLE DE DIAPHRAGME



Thickness / *Epaisseur* = 6.75 ±0.15 mm

REF.15 - P. N° 141-89  
PUMP COVER  
CORPS DE POMPE A ESSENCE



Thickness / *Epaisseur* = 12.5 ±0.15 mm

REF.37 - P. N° 14-A96  
 THROTTLE SHUTTER  
 PAPILLON

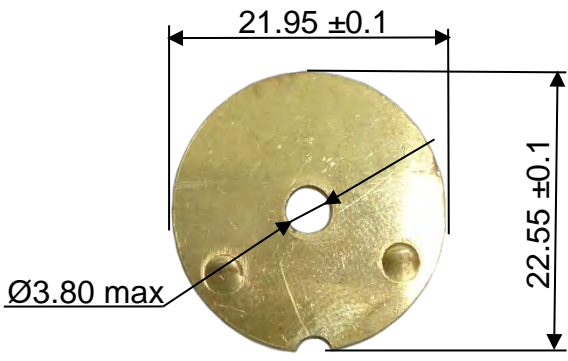

Thickness / Epaisseur = 0.81 ±0.1 mm

REF.27 - P. N° 233-720P  
 SEAT + NEEDLE  
 SIEGE + POINTEAU

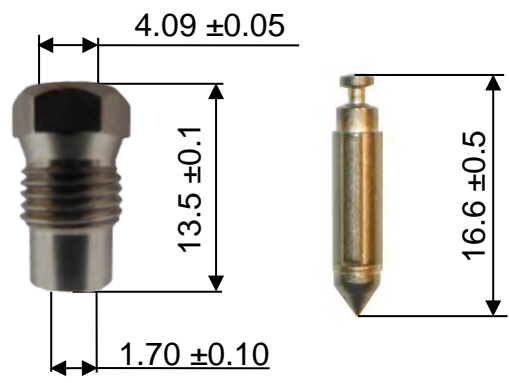

REF.21A - P. N° 43-1034  
 NEEDLE LOW SPEED  
 VIS DE RAGLAGE BAS-REGIME

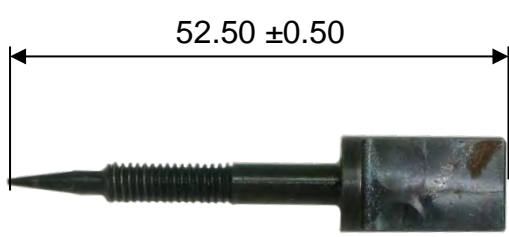

REF.30A - P. N° 43-1034  
 NEEDLE HIGH SPEED  
 VIS DE RAGLAGE HAUT-REGIME

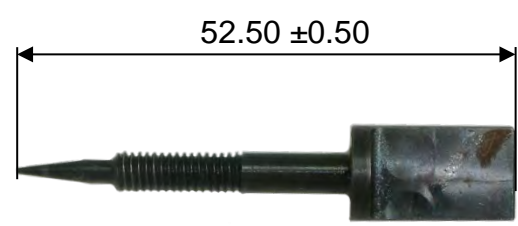

NEEDLE FUEL ALTERNATIVE  
 POINTEAU ALTERNATIVE

REF.27 - P. N° 233-720P



HOLE FOR CARBURETTOR SEALING  
 TROU POUR LE PLOMBAGE

The carburettor can have this hole for sealing.  
 Le carburateur peut avoir ce trou pour le plombage

